

MPS-3600 series (Preliminary) Intelligent Pressure Sensor

■ Features

- SMD package
- 1, 5.8, 15, 30 psi differential pressure range
- Operating temperature range: -40 to 85°C
- MEMS piezoresistive sensing element
- Easily Embedded in OEM Equipment

■ Applications

- Airflow meter
- Ventilation and air flow monitors
- Sleep apnea monitoring and therapy equipment
- Pneumatic controls
- HVAC

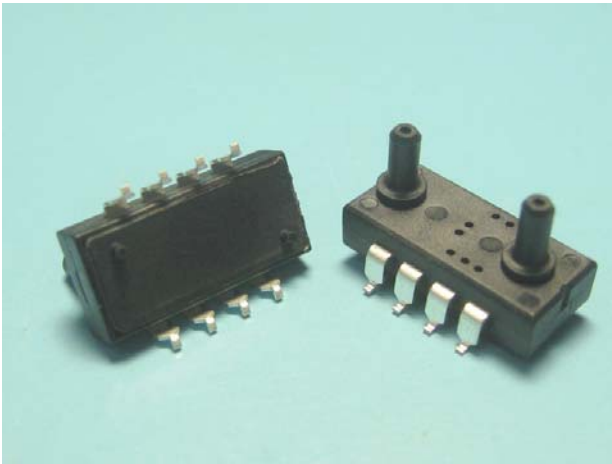

The MPS-3600 is a differential type pressure sensor which consist of a MEMS piezoresistive pressure sensor chip. It is available in pressure range as 1, 5.8, 15 and 30psi. The state of the art MEMS sensing core make the sensor high linearity, low hysteresis, low power consumption, high reliability and miniature body figure.

■ Package Outlines

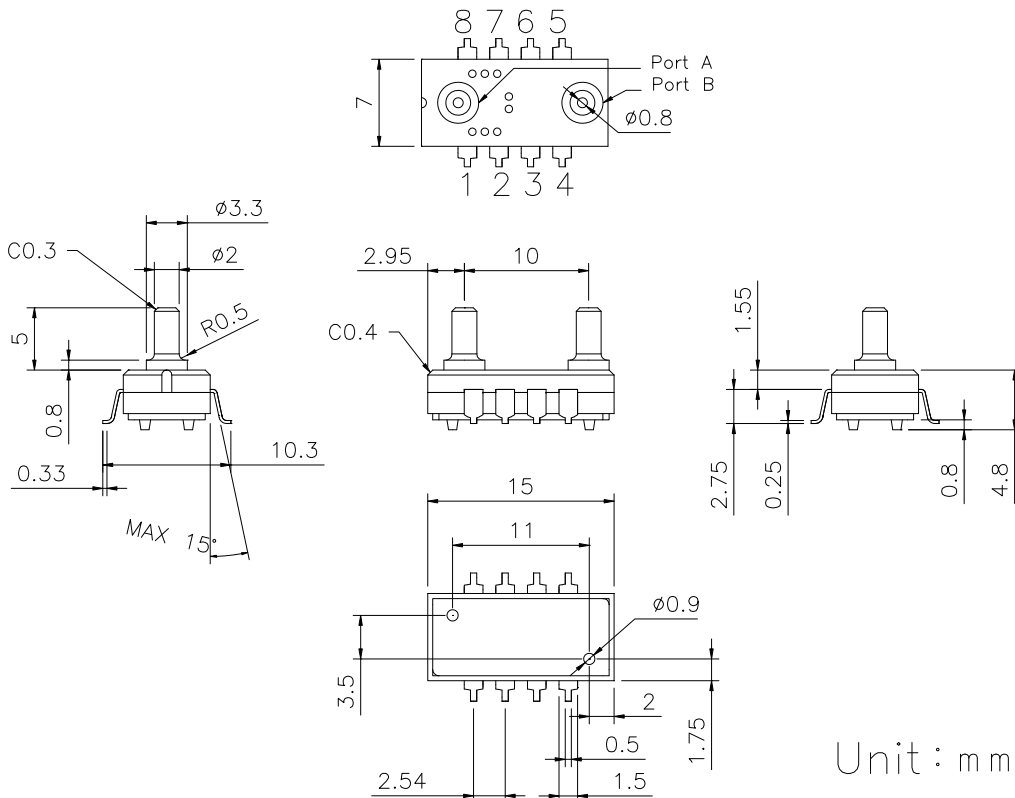

■ Specifications

Parameter	Min	Typ	Max	Units	Notes
General					
Pressure Range	1 · 5.8 · 15 · 30			PSI	(6)
Maximum Overpressure			2X		Rated pressure
Operating Temperature Range	-40		85	°C	-40 °F ~ +185 °F
Storage Temperature Range	-40		125	°C	-40 °F ~ +257 °F
Operating humidity	0		95	% RH	No condensation
Media Compatibility	Clean, dry air & noncorrosive gases				
Electrical performance⁽¹⁾					
Excitation voltage	2	5	15	Vdc	
Excitation current	0.4	1.5	3	mA	
Bridge resistance	4	5	6	kΩ	
Offset Voltage	-25		25	mV	
Full Scale Span Voltage					
1 PSI	20	30	40	mV	
5.8 PSI	50	75	100		
15 PSI	70	100	130		
30 PSI	80	110	140		
Linearity					
1 PSI	-0.7	0.15	0.7	% Span	(2)
5.8, 15, 30 PSI	-0.3	0.05	0.3		
Temperature Coefficient of Zero Offset (TCO)					
1 PSI	-0.22		0.22	% Span/°C	(3)
5.8, 15, 30 PSI	-0.08		0.08		
Temperature Coefficient of Span (TCS)	-0.16	-0.21 ⁽⁴⁾	-0.26	%Span/°C	Const. Voltage excitation (3)
	-0.05	0.025 ⁽⁵⁾	0.05		Const. Current excitation (3)
Temperature Coefficient of Resistance (TCR)	0.17	0.2	0.23	%/°C	(3)
Notes :					
1. Unless otherwise specified, measurements were taken with a supply voltage of 5 Vdc at a temperature of 25±3°C and humidity ranging from 25% ~ 85% .					
2. Best fit straight line.					
3. Between 0 °C and 50 °C. Temperature coefficients are typical values.					
4. Measured only with constant voltage excitation (5V) .					
5. Measured only with constant current excitation (1mA) .					
6. Pressure range was defined as pressure of port A subtract pressure of port B.					
Metrodyne Microsystem Corp. reserves the right to make changes to the product specification in this publication.					

■ Ordering information

Part No.	Pressure type	Pressure range	Feather	Note
MPS-3600-001D	Differential	1 PSI	5kOhm	
MPS-3600-006D	Differential	5.8 PSI	5kOhm	
MPS-3600-015D	Differential	15 PSI	5kOhm	
MPS-3600-030D	Differential	30 PSI	5kOhm	

■ Pin Configuration and Function Descriptions

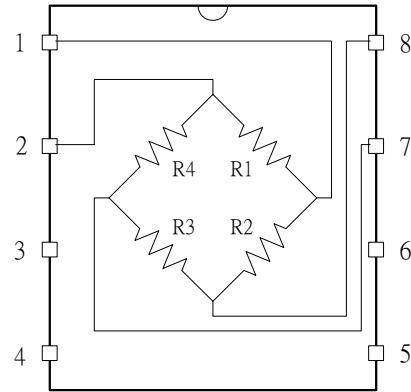
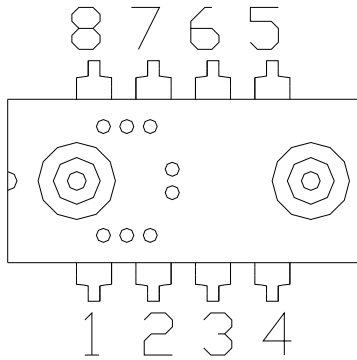

Pin configuration of MPS-3600

Pin No.	Pin Name	Description
1	+Vin	Supply voltage
2	-Vout	Negative output voltage
3	NC	No connection
4	NC	No connection
5	NC	No connection
6	NC	No connection
7	-Vin	Gnd
8	+Vout	Positive output voltage

■ Recommended footprint

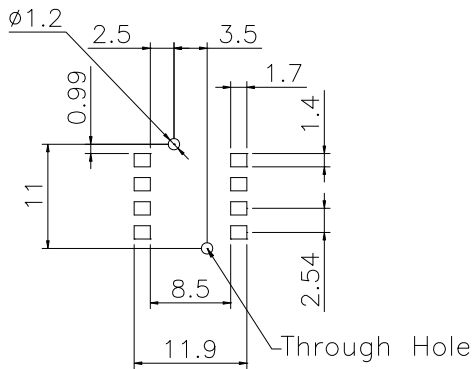

Unit:mm

■ Metrodyne Microsystem Corp.

10, Prosperity Rd. II, Science-Based Industrial Park, Hsin-Chu 300, Taiwan, R.O.C.

Tel:886-3-5632161 Fax:886-3-5632509

E-mail:sales@metrodyne.com.tw <http://www.metrodyne.com.tw>