

MIS-3600 series (Preliminary) Intelligent Pressure Sensor

■ Features

- Supply Voltage 2.0 to 3.6V
- 0.5, 1, 5.8, 15, 30 psi differential pressure range
- Low standby current: <math><0.1\mu\text{A}</math>
- Factory calibrated and temperature compensated
- SPI and I2C digital signal output

■ Applications

- Airflow meter
- Ventilation and air flow monitors
- Sleep apnea monitoring and therapy equipment
- Pneumatic controls
- HVAC

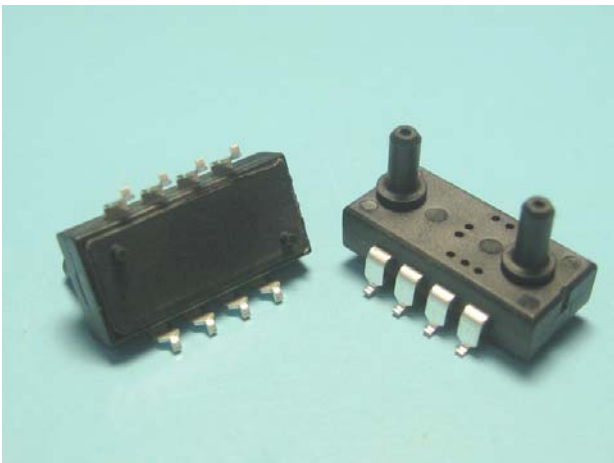

The MIS-3600 is an intelligent pressure sensor which consist of a MEMS piezoresistive pressure sensor and a signal conditioning ASIC. The signal conditioning ASIC is a 16-bits AD convertor with embedded 512 bits

OTP memory. The sensor was calibrated and temperature compensated in factory. The factors for temperature compensation were stored in OTP memory. Users can implement temperature compensation via an external micro processor. The external microprocessor read the raw output data from MIS-3600 and do simple calculation according to the factors stored in OTP memory. Therefore using MIS-3600 series is easy to get rid of bothersome calibrations and temperature compensations. MIS-3600 provide SPI or I2C digital serial output interface to communicate with microprocessors. MIS-3600 series is specially designed for low voltage and low power consumption concerned applications.

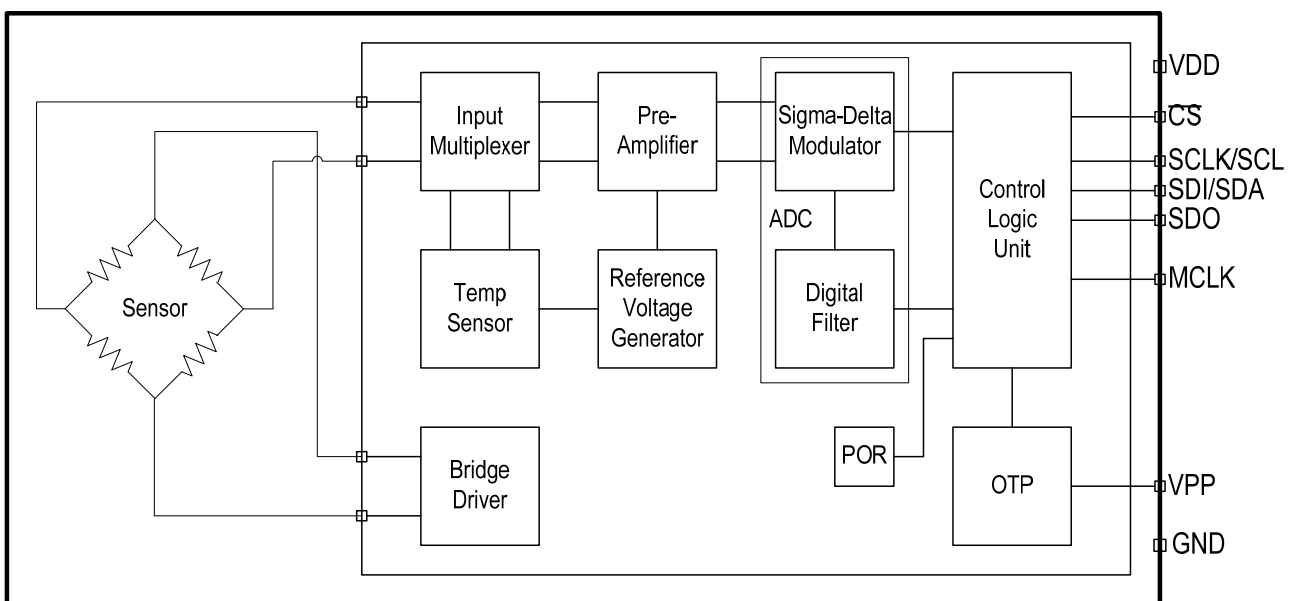

Fig. 1 Functional Block Diagram of MIS-3600

■ Specifications

Parameter	Symbol	Conditions	Min	Typ	Max	Units	Notes
1. Absolute Maximum Ratings							
Supply Voltage	VDD		-0.3		4	V	
Inputs voltage to VSS			-0.3		VDD+0.3	V	
Storage Temperature Range			-40		125	°C	
Maximum Overpressure					2X	Rated pressure	
ESD Rating							
HBM			4000			V	
MM			400				
2. Recommended Operating Conditions							
Pressure Range			0.5, 1, 5.8, 15, 30			psi	3
Operating Temperature Range			-40		85	°C	
Humidity			0		95	%RH	
Supply Voltage	VDD		2.0	3	3.6	V	
Supply Current		VDD=3V					
Peak Current During Conversion	I _{sc}			600		μA	
Standby	I _{ss}			0.1	0.5	μA	
Average	I _{avg}	1 conversion/s		21.6	30.5	μA	
Conversion Time	t _{conv}	MCLK=32.768kHz		34.5		ms	
External clock signal	MCLK		30000	32768	35000	Hz	
Duty cycle of MCLK			40	50	60	%	
Serial data clock	SCLK				500	kHz	
3. Electrical Parameters							
Analog to Digital Converter							
Resolution				16		Bits	
Output Code Range			2048		63487		
Conversion Time	t _{conv}	MCLK=32.768kHz		34.5		ms	
Output update rate					25	Hz	
Integral Nonlinearity			-4		+4	LSB	TBD
Differential Nonlinearity			-1		+1	LSB	TBD
SPI Interface							
Digital Inputs							
Serial data clock					500	kHz	
Input High Voltage	V _{IH}	I _{IH} < 5μA	80%VDD		VDD		
Input low Voltage	V _{IL}	I _{IL} < 5μA	0		20%VDD		
Input leakage current					0.1	μA	
Rise time	t _r				200	nS	
Fall time	t _f				200	nS	
Digital Outputs							
Output High Voltage	V _{OH}	SDO, I _{source} =0.6mA	80%VDD				
Output low Voltage	V _{OL}	SDO, I _{sink} =0.6mA			20%VDD		
Output low Voltage	V _{OL}	SDI, I _{sink} =1.0mA			20%VDD		
Rise time	t _r	C _{load} = 50pf			200	nS	
Fall time	t _f	C _{load} = 50pf			200	nS	
Pressure Output Characteristics							
Full scale range							
0.5, 1psi			11	11.6	12	bits	
5.8psi			12.4	12.9	13.4		
15psi			12.8	13.4	13.7		
30psi			13	13.5	13.8		
Pressure Accuracy		T=-40~-20°C		±2		%FS	2
0.5psi, 1psi		T=-20~70°C		±1			
		T=70~85°C		±2			

Pressure Accuracy 5.8psi · 15psi · 30psi		T= -30~85°C T= -40~-30°C		±1 ±2		%FS	2
Temperature Output Characteristics							
Resolution				0.1		°C	
Accuracy		-40 to 85°C	-2		2	°C	
Notes :							
<ol style="list-style-type: none"> 1. Unless otherwise specified, measurements were taken with a supply voltage of 3 Vdc at a temperature of 25±3°C and humidity ranging from 0~95% RH. 2. Maximum error of pressure reading over compensated temperature range and pressure range. That include all errors resulted from offset, span, linearity, temp. drift of offset and temp. drift of span. 3. Pressure range was defined as pressure of port A subtract pressure of port B. (Please refer to the drawing on page 12) 							
Metrodyne Microsystem Corp. reserves the right to make changes to the product specification in this publication.							

■ Pin Configuration and Function Descriptions

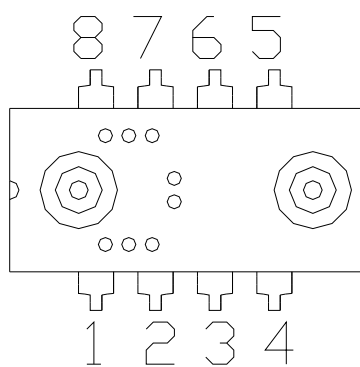
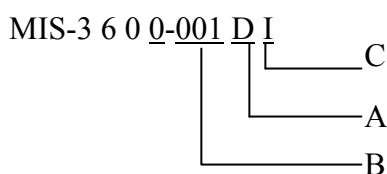

Fig. 2 Pin configuration of MIS-3600

Pin No.	Pin Name	Description
1	VPP	OTP Programming Voltage.
2	CS	Chip Select Input. Control data conversion timing and enables the serial input/output register.
3	GND	Ground.
4	SCLK/SCL	External Clock Input. This clock synchronizes serial data I/O.
5	SDO	Serial Data Output. Data is shifted on the RISING edge of DCLK. This output is high impedance when CS ₁ is HIGH.
6	SDI/SDA	SPI Serial Data Input I2C data I/O
7	MCLK	External Clock Input. This clock runs the A/D conversion process.
8	VDD	Power Supply.
<p>Note! Pin1 was used only for calibration by the manufacturer and should not be connected.</p>		

■ Ordering information



A	Pressure type	B	Pressure range
D	Differential bipolar	C50	0.5 PSI
S	Differential unipolar	001	1 PSI
		006	5.8 PSI
		015	15 PSI
		030	30 PSI
C	Interface		
I	I2C		
S	SPI		

Part No.	Pressure type	Pressure range	Digital interface	Note
MIS-3600-C50DI	Differential bipolar	-0.5~0.5 PSI	I2C	
MIS-3600-C50SI	Differential unipolar	0~0.5 PSI	I2C	
MIS-3600-C50DS	Differential bipolar	-0.5~0.5 PSI	SPI	
MIS-3600-C50SS	Differential unipolar	0~0.5 PSI	SPI	
MIS-3600-001DI	Differential bipolar	-1~1 PSI	I2C	
MIS-3600-001SI	Differential unipolar	0~1 PSI	I2C	
MIS-3600-001DS	Differential bipolar	-1~1 PSI	SPI	
MIS-3600-001SS	Differential unipolar	0~1 PSI	SPI	
MIS-3600-006DI	Differential bipolar	-5.8~5.8 PSI	I2C	
MIS-3600-006SI	Differential unipolar	0~5.8 PSI	I2C	
MIS-3600-006DS	Differential bipolar	-5.8~5.8 PSI	SPI	
MIS-3600-006SS	Differential unipolar	0~5.8 PSI	SPI	
MIS-3600-015DI	Differential bipolar	-15~15 PSI	I2C	
MIS-3600-015SI	Differential unipolar	0~15 PSI	I2C	
MIS-3600-015DS	Differential bipolar	-15~15 PSI	SPI	
MIS-3600-015SS	Differential unipolar	0~15 PSI	SPI	
MIS-3600-030DI	Differential bipolar	-30~30 PSI	I2C	
MIS-3600-030SI	Differential unipolar	0~30 PSI	I2C	
MIS-3600-030DS	Differential bipolar	-30~30 PSI	SPI	
MIS-3600-030SS	Differential unipolar	0~30 PSI	SPI	

■ Package Outlines

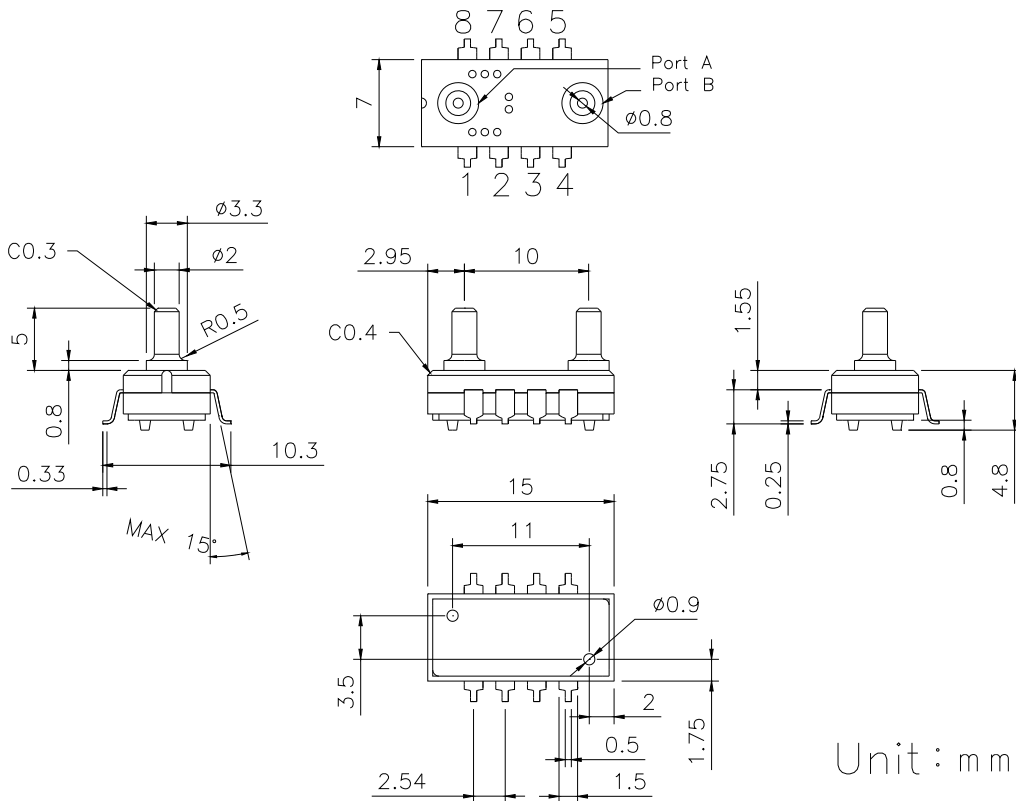

Fig. 3

■ Recommended footprint

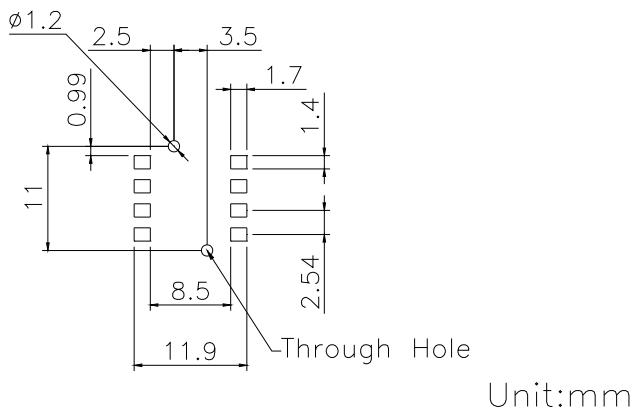

Fig. 4

Metrodyne Microsystem Corp.

10, Prosperity Rd. II, Science-Based Industrial Park, Hsin-Chu 300, Taiwan, R.O.C.

Tel:886-3-5632161 Fax:886-3-5632509

E-mail:sales@metrodyne.com.tw <http://www.metrodyne.com.tw>